

**OLD DOG
ELECTRONICS**

Parys, Free State, RSA
+27-72-619-1323
olddogelectronicsza
@gmail.com
olddogelectronics.co.za

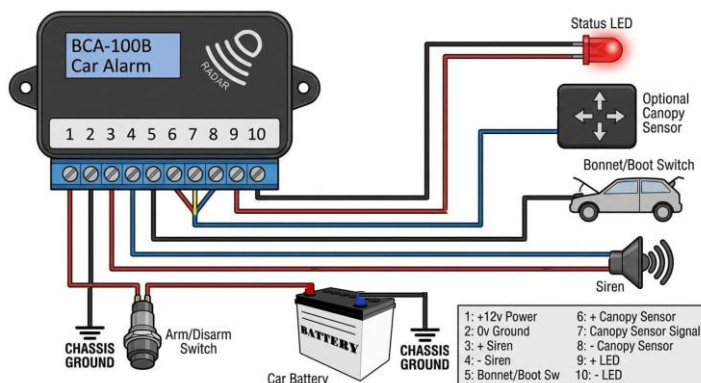

BCA-100B Basic Car Alarm Compact, Reliable Protection

The BCA-100B Basic Car Alarm is designed to deliver maximum security with minimum fuss. Built for simplicity, reliability, and owner-friendly installation, it offers peace of mind without unnecessary complexity.

- Ultra-compact design — smaller than a standard 20-cigarette packet, making it easy to conceal.
- Effortless installation — **requires only a single wire connection to the vehicle's electrical system**, no extra wiring needed to protect all doors and the hatchback tailgate.
- Advanced radar movement sensor — ensuring your vehicle is safeguarded against unauthorised access.
- Jam-proof security — engineered to be 100% immune to remote jamming attacks.
- Hidden push-button control — discreet arming and disarming without the need for remote controls.
- Microprocessor-controlled stability — ensures consistent, reliable operation under all conditions.
- Optional bonnet and boot protection — expandable inputs allow you to secure extra entry points if desired.
- Owner-installation friendly — designed for straightforward set-up, avoiding costly professional fitting.
- Ultra-low power consumption — draws less than 10 mA, preserving your battery life.
- Clear status indication — built-in LED displays the alarms condition at a glance.
- Serviceable design — uses standard, uses readily available components for long-term reliability.
- 12-month warranty — backed by a full year of manufacturer support for added confidence.

Note: The alarm is not VESA approved.

How does it work?

The alarm uses a radar module to detect movement inside the vehicle . The microprocessor monitors the radar module, controls entry and exit delay's, and prevents false alarms.

When switched on, the alarm has a 10sec exit delay for all the doors to be closed before arming.

The alarm continually checks for movement plus the bonnet and boot (if the switches are installed).

Should the bonnet, boot, be opened whilst the alarm is armed, the siren will sound immediately for 120sec after 120sec,the alarm will reset.

When a door is opened, the alarm is triggered but has a 4sec entry delay before the siren sounds. If the alarm isn't disabled within the entry delay period, the siren will sound for 120sec. After the 120sec, the alarm will reset if no further movement is detected. The alarm will indicate it has been triggered by the status LED flashing approx twice per second.

What's In The Box	
	BCA-100B Module
	Arm/Disarm Switch With Wiring
	Pre-wired LED
	Pre-wired Siren
	Pre-wired Bonnet Switch (Optional)
	Mounting Hardware

Prices	
BCA-100B c/w All Associated Hardware Excluding Optional Bonnet Switch	R550.00
Optional Bonnet Switch	R45.00
Shipping We use Paxi, The Courier Guy, Postnet	Cost plus 5%